

Product lettering

3.1 Overview

This is an overview of the stickers to be placed on our crane girders.

The sizes and ID numbers can be found on the following pages.

For the V-type crane, please note that the signs with logo and size are made on order as their size depends on the angle of the truss.

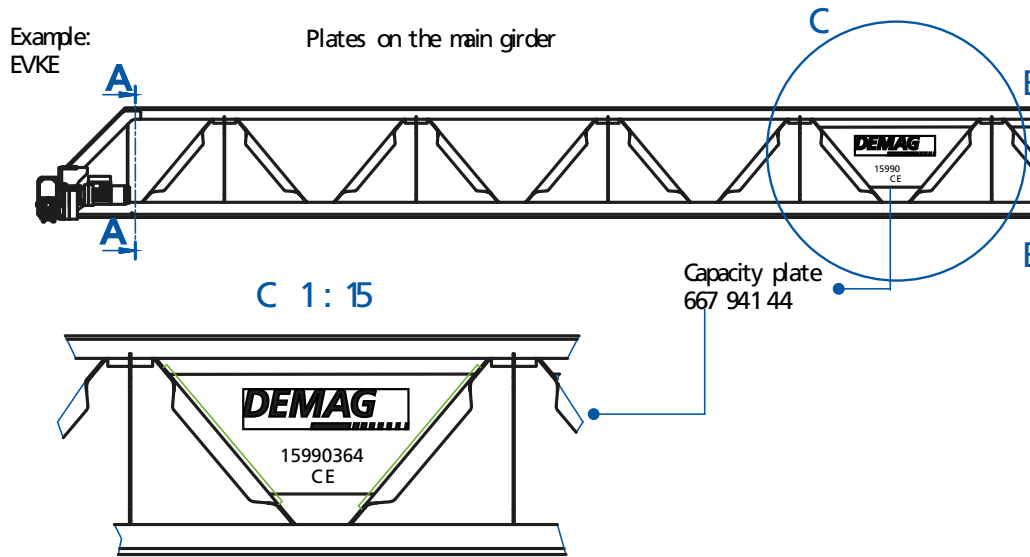

KTD-E 953 320 44
DFW-D-L, DFW-D-E 655 190 44

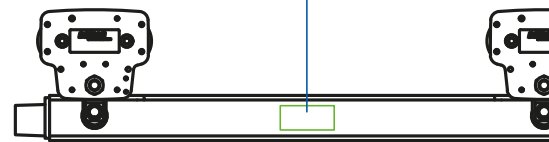

EKKE, EPKE, ZKKE, Tandem

Fival inspection of
mechanical/electrical
equipment
237 097 44

Inspection plate
658 300 44

Maker's plate
658 299 44 Standard
651 079 44 Sonder/Spe

EKDE, EPDE

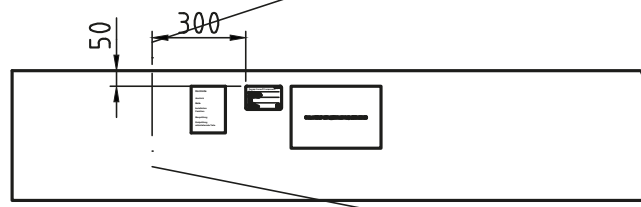

All standard and extra plates are applied with adhesive.

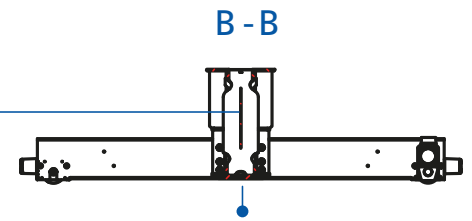
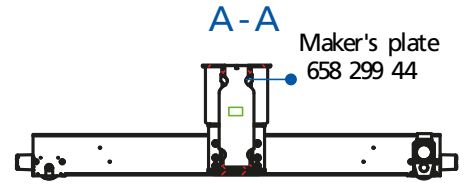
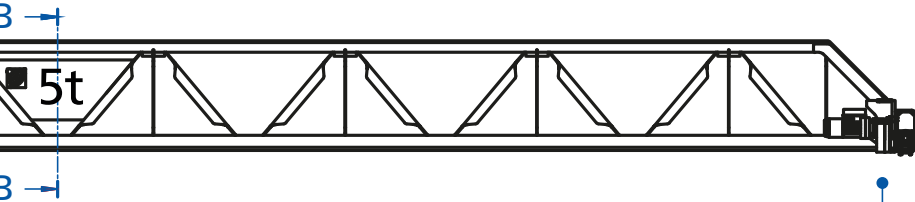

Plates on the end carriage

High-strength bolts connection plate

Adhesive surfaces at diagonal bars clean.
Grease and dust
Positioning the carrier profiles centered on the diagonal bar.

DFW-L-E, DFW-L-Z beim EVKE, ZVKE 964 385 44, 658 300 44, 237 097 44
DFW-L-E, DFW-L-Z, DFW-L-T 964 385 44

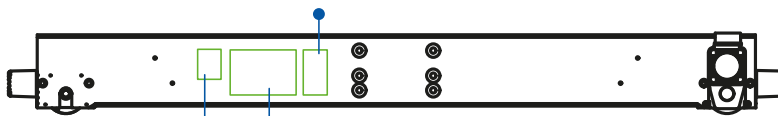

Fival inspection of
mechanical/ electrical
equipment
237 097 44

Inspection plate
658 300 44

Number with CE sign
and year of construction

DEMAG

10 t

Nr.3456 **CE**
Ar 2012

Load capacity in ..t see 651 079 44

Demag product logo see 651 079 44

DFW-L-E, DFW-L-Z, DFW-L-T
964 385 44

KTD-E 953 320 44
DFW-D-L, DFW-D-E 655 190 44

